



Geography
YEAR 8

Table of Contents

Introduction	2
The aims of Geography in the Curriculum	2
Approaches to teaching and learning for Geography	3
Assessment in Geography	6
Learning Outcomes	10
Kisbiet mit-Tagħlim	11
Assessment Criteria	12
Kriterji tal-Assessjar	14
Scheme of Assessment	16
School-Based Assessment Tasks	17
Marking Criteria	20
Reporting to parents/guardians	23
List of Geographical terms – English to Maltese	24
Appendices	27
Mudell Assessjar Kontinwu - Żbroff ta' vulkan	28
Sample School Based Assessment – All around the world	33
Mudell tal-karta tal-eżami	36

Introduction

This syllabus is based on the curriculum principles outlined in the *The National Curriculum Framework for All* (NCF) which was translated into law in 2012 and designed using the *Learning Outcomes Framework* that identify what students should know and be able to do by the end of compulsory education. It is linked to the national curriculum learning area Humanities Education and builds on the knowledge and skills students have acquired previously in the Primary years of schooling.

This learning outcomes-based programme addresses the holistic development of all learners and advocates a quality education for all as part of a coherent strategy for lifelong learning. It ensures that all children have the opportunity to obtain the necessary skills and attitudes to be future active citizens and to succeed at work and in society irrespective of socio-economic, cultural, racial, ethnic, religious, gender and sexual status. This learning and assessment programme provides equitable opportunities for all learners to achieve educational outcomes at the end of their schooling which will enable them to participate in lifelong and adult learning, reduce the high incidence of early school leaving and ensure that all learners attain key competences required in the 21st Century.

This programme also embeds learning outcomes related to cross-curricular themes, namely digital literacy; diversity; entrepreneurship creativity and innovation; sustainable development; learning to learn and cooperative learning and literacy. In this way students will be fully equipped with the skills, knowledge, attitudes and values needed to further learning, work, life and citizenship.

This Geography learning and assessment programme enables students to develop spatial understanding of the local, regional and global environment as well as physical, economic and political interactions within and between communities. It encourages learners to acquire an understanding of sustainable development and an awareness of the need to conserve the environment for future generations. It provides students with the opportunities to explore certain themes in the physical and human fields of geography in a practical way, both inside the classroom through case studies and outside the classroom through fieldwork.

The aims of Geography in the curriculum

Geography as a discipline enables us to understand the Earth we are living in from a spatial perspective. As a school subject it enables students to explore and understand the relationship between human beings and the Earth through the study of space, place and the environment. Geography makes both a distinctive and a wider contribution to the curriculum. It is an essential component in preparing young people for life in the twenty-first century. As the pace of change quickens, communications get faster and challenges to the environment multiply, a knowledge and understanding of geography is more vital than ever. Geographical education is indispensable to the development of responsible and active citizens in the present and future world. Geography can be an informing and stimulating subject at all levels in education, and contributes to a lifelong enjoyment and understanding of our world. Learners require global geographical awareness in order to ensure effective cooperation on a

broad range of economic, political, cultural and environmental issues in a shrinking world. Geography addresses the major challenges that the global community is facing. The resolution of major issues facing our world requires the full commitment of people of all generations.

The aims of the curriculum are:

- to develop in young people an interest in and a sense of wonder about the place where they live in, of other places and people; in particular the spatial arrangement of different environments, the processes that shape our world, and how people and environments inter-relate and interconnect;
- to enable students become informed, responsible and active global citizens by fostering an appreciation of environments, thereby enhancing a sense of responsibility for other people and the long-term sustainability of the planet;
- to prepare students to think and enquire in a geographical way equipping them to discovery, gather, organize, analyse, use and present new geographical knowledge obtained from maps, data, digital technologies and fieldwork in order to make sense of new situations.

Approaches to teaching and learning for Geography

Geography stimulates an interest in and a sense of wonder about places. This sense of wonder and the complexity of the world can best be achieved through a range of methodologies requiring an enquiry approach for the investigation of the location, situation, interaction, spatial distribution and differentiation of features. The learning process centres more on students' activities such as group work, than on the passive reception of knowledge and understanding through teacher exposition. Students should be active in the learning process and they acquire knowledge and develop skills through fieldwork and out of class learning, through the use of Information Technology, resources including maps, as well as games, simulations and role play. An enquiry can be based on a single resource such as a map, a photograph, an item from the internet, statistics from which students extract data, ideas, facts and attitudes to answer a geographical question or solve a problem. Such questions can come directly from students through discussion. The use of group work helps to facilitate the active characteristics of much enquiry work.

Geography is the discipline which seeks to explain the character of places and the distribution of features and events as they occur and change the surface of the earth. Geography is concerned with human – environment interactions in the context of specific places and locations. In addition to its central concern with space and place, it is characterised by a breadth of study, a range of methodologies, a willingness to synthesise work from other disciplines and an interest in the future of people – environment relationships.

Geography often starts with the following questions:

- Where is it?
- What is it like?

- Why is it there?
- When did it happen and how does it change?
- What impacts does it have?
- How should it be managed for the mutual benefit of humanity and the natural environment?

Finding answers to these questions requires investigation of the location, situation, interaction, spatial distribution and differentiation of features. Explanations of current situations come from both historical and contemporary sources. Trends can be identified which indicate possible future developments. Some of the central concepts of geographical studies are location and distribution, place, people-environment relationships, spatial interaction and regions.

Learning through fieldwork

Fieldwork provides opportunities for first-hand investigation of people in their environment and as such awakens students to a diversity of environments and cultures, in their local area and beyond. It teaches students to collect, analyse and present data, sharpening their observations, measuring, recording and evaluation skills. Fieldwork has important contributions to make geography real and enjoyable and as a result every geography student should be entitled to have a reasonable amount of exposure to fieldwork experience through the geography course. Fieldwork should not be limited to visits and guided tours, whereby students are involved only in passive activities such as listening, observing and note-taking. Fieldwork should be enquiry-based in-line with the aims and objectives of this curriculum. It should involve students in identification of an issue or problem in a specific area, collect, present and analyse data and finally identify possible solutions or strategies.

Learning through maps

Maps in the form of paper, digital images and globes are an important tool for geographers and enable us to record, display and analyse information about people and environments. Teachers should ensure that their students are able to master a reasonable level of mapping skills and integrate such skills into the learning and teaching of geographical issues in the curriculum. Understanding and using maps involve the simultaneous use of a number of concepts and skills including aerial perspective, proportion, map language and arrangement. Students should be given the opportunity to develop their map literacy so that they can use maps to find out about and interpret the world around them in a critical informed way. In an enquiry based approach students should have access to a wide range of maps including large wall maps, atlases, globes, maps on CD-ROMs and other electronic media, including Google Map and Google Earth.

Learning through information technology

Information and Communications technology, whether it is a personal computer, an interactive whiteboard or a mobile phone, influences how students make sense of their world today and at the same time offers a range of tools to support their geographical understanding. Specific programs, such as Google Earth, can improve spatial thinking and electronic media and the internet enables students to gain up-to-date information and access a vast range of images, videos, data and other sources which can enrich geographical understanding. By using IT teachers can make lessons enjoyable thus enhancing students'

learning motivation. Geography teachers should provide adequate opportunities for their students to apply IT in their enquiry-based approach because IT:

- provides a range of information sources to enhance geographical understanding
- supports the development of a body of geographical knowledge
- provides images of people, places and environments
- helps students develop their ideas using ICT tools to amend and refine their work and enhance its quality and accuracy
- helps students exchange and share information, both directly and through electronic media
- provides students with the ability to review, modify and evaluate their work, reflecting critically on its quality as it progresses
- contributes to pupils' awareness of the impact of information systems on the changing world
- contributes substantially to the development of a range of IT capabilities, especially with regards to data handling, use of communication technologies and information sources and modelling
- develops the students' skills in the following IT toolkit namely word processor; spreadsheet; presentation software; desktop publishing (DTP) software; internet browser/e-mail; electronic atlas; electronic encyclopaedia; geographic information system (GIS); automatic datalogging weather station; digital camera.

This programme provides opportunities for using IT and a wide range of approaches will be used to develop students' IT capability and enhance the quality of their geography experience.

Learning through the use of resources

A good geographical enquiry usually involves the use and analysis of a rich variety of resources including worksheets, textbooks, maps, models, computer software, interactive games, the internet, newspaper resources, weather instruments, specific items (rock samples and tools) and many others. Very often such resources arouse students' motivation and engage them in active learning situations that meet their varied needs. Besides this, such an extensive range of resources enhance students' learning experiences and are seen by many as a key attraction of the subject. Ideally geography should be taught in a special room which includes:

- adequate space for students preferably equipped with desks with flat surfaces for practical work especially map work;
- spacious environment for the storage and effective use of resources including, maps, books, charts, apparatus, posters and handouts;
- various kinds of wall maps including those of the Maltese Islands, the Mediterranean region, Europe and the World;
- globes, including political, relief and activity globes that can be marked and cleaned;
- meteorological and fieldwork instruments;
- computers with internet access;
- interactive whiteboard;
- water supply for use in simple experiments and model making.

Students should be encouraged also to handle and use such resources during breaks or when geography related extra-curricular activities are being organised in school.

Assessment in Geography

Assessment in geography must assess the student's understanding and application of the main geographical concepts and knowledge, the acquisition of basic geographical skills and the development of attitudes and values contributing to sustainable development. A range of assessment techniques will be necessary and all of these approaches should arise as naturally as possible for students to perform to their true ability.

The following list includes examples of different modes of assessment that may be considered by educators:

- map reading exercise
- oral presentation
- debate
- role play
- research work from Internet and books
- free-response writing or essay writing
- data-response tasks
- labelling and sketching of diagrams
- designing an advert, flyer or poster
- model-making
- active participation in a co-curricular project
- experiments
- structured questions
- mind maps
- reporting on site visits
- commenting on videos
- use of online sources and software to locate places
- analysis of newspaper articles
- self-assessment through checklist
- quiz
- problem-solving activity
- resource-based questions

The most valuable information about students' achievements comes from day-to-day observations, especially through effective questioning and discussions as the students work. Such information is necessary to make judgments of what they know, what are their strengths, weaknesses and misconceptions; thus adjusting the pace and choosing the most appropriate teaching strategies to reach the learning objectives. This can be achieved through:

- observation and listening to students as they work;
- the responses the students make to questions set;

- participation of the student in discussions;
- marking and providing quality feedback to student's work;
- reflecting on and critically evaluating their own work as well as through the involvement of students in peer assessment processes.

Valuable information about students' attainment can also be observed and assessed while students are engaged in a range of classroom situations. These activities may include:

- collecting information from primary and secondary sources;
- direct observation in the field;
- predicting outcomes after conducting simple experiments;
- completing work cards or handouts;
- oral presentations;
- written work or class tests;
- drawing and analysing maps;
- using and interpreting graphs;
- collecting information from electronic media;
- carrying out independently geographical research and recording and presenting results in project work.

The use of a range of tasks incorporating different levels of difficulty and in diverse modes will enable the teacher to assess more accurately the level of geographical understanding of students with different aptitudes and abilities.

These types of formative assessment procedures give teachers the most valuable information about students' attainments and have the most impact on their progress. However, summative assessments such as the annual examinations set by the Education Assessment Unit should not be used simply to rank students' performance or perhaps to inform parents about students' attainment. Such examinations can also have a formative element by encouraging students to reflect on their performance, and at the same time helping teachers evaluate the success of their teaching and setting targets for improvements. Students' progress can be documented and assessed through the collection of a range of samples of their work in geography portfolios. It may contain a small sample of evidence which exemplifies student's efforts and may include map work, photographs of models constructed, write ups and images of places visited, record sheets from experiments, together with student's written work in the form of handouts or research work from secondary sources such as the internet.

Assessment for learning

Assessment for Learning (AfL) occurs when evidence is used to adapt the teaching to meet the needs of the students. Assessment for Learning enhances learning for all types of students because it is there to build a bridge between what is known and what lies on the next step.

1. Understanding what students know

Before starting to teach a new topic or concept, we need to become aware of what are the pupils' perceptions on the subject. Techniques that can be used include brainstorming, questioning, survey, concept mapping, mind web, discussion, short test, evaluate written work done at home or at school.

2. Effective Questioning Techniques

We should consider the use of open challenging questions which allow a range of correct responses and require students to think. More wait time is required. This wait time has to be of around five seconds. Students usually leave the answering of questions to the few most able students in class or else when we use a 'hands up' technique, only those that are sure of the answer put up their hand as the others would not want to risk. What about the rest of the students? How will we know that these students have grasped the concept or the skill? Therefore avoid the hands up technique and give everybody an opportunity to answer. Questions can be of the following type:

- **Literal Questions**
Simple recall: Who? Where? When? What?
- **Application Questions**
Can you think of another situation similar to this? Do you know of another story that deals with the same issues? Do you know where else this can be used?
- **Analytical Questions**
What makes you think that? Can you support your view with evidence? Why do you think this was written/given in such a way? Why did you decide to do it in such a way?
- **Synthesis Questions**
What is your opinion? What evidence do you have to support your view? Given what you know about... what do you think? If you were ...what would you think
- **Evaluation Questions**
What makes this... successful? Does it work if done in another way? Which is better and why?

3. Oral Feedback during the lesson

Feedback is fundamental. It gives the opportunity to students to improve in their learning. Feedback has to be from teacher to student, student to teacher and student to student. Good oral feedback should:

1. focus on the student's work not on the person
2. state specific ways on how the work can be improved
3. compare the work the student produced with what was previously done
4. do it all along the activity
5. be critically constructive use
6. comments that push the learning forward
7. use a language that does not intimidate the students
8. consider all the students' comments
9. focus on the learning intentions explained at the beginning

4. Oral and Written Feedback after the lesson

'It is the nature, rather than the amount, that is critical when giving pupils feedback on both oral and written feedback'. (Black 2004)

Written feedback can be in the form of grades or comments or both. A numerical mark does not tell the students what needs to be improved in their work and therefore an opportunity to enhance their learning is lost. When a comment is written next to the grade, students tend to ignore the comment and all the corrections the teacher does. The mark becomes a measure of their ability.

Give students the correct advice that would lead them to correct their mistakes. This advice has to be concordant with the learning intention. The advice should be a very short piece of information about where the students achieved success and where they could improve to achieve the learning intention.

The work should go back to the student who must be given time to carry out the requested changes. The work will then go back to the teacher who will correct it and give another advice on what can be done next to enhance learning.

Comments need to begin with what has been a success, move on to show what needs to be improved and give advice on how this improvement can be achieved. It should focus on specifics by asking a specific question about what went wrong and ask questions that prompt a student to be more specific. The feedback given should stimulate the student to improve. It should be challenging enough to motivate the students to learn. Visible improvements will increase the students' self-esteem.

LEARNING AND ASSESSMENT PROGRAMME

Learning Outcomes

YEAR 8	
8.1	I can use aerial photos, maps, the internet, interactive maps and software to locate various key physical and human features of Malta, the Mediterranean, Europe and the wider world.
8.2	I can interpret a map showing time zones and describe the connection between the Earth's rotation and time.
8.3	I can research a case study to describe the characteristics and effects of any one of the following types of natural disasters such as hurricanes, flooding, tsunami, wildfires, sandstorms, avalanches and blizzards.
8.4	I can outline the main cause of plate movements and its main effects on the landscape, namely earthquakes, volcanoes and fold mountains.
8.5	I can research a case study of an earthquake and of a volcano to illustrate their effects.
8.6	I can give some reasons why people choose to live in tectonically active zones as well as discuss appropriate strategies to save lives.
8.7	I can recognise the landscape and climate of a hot and a cold desert and list some adaptations of vegetation and animals to survive these environments.
8.8	I can explore how people exploit hot and/or cold deserts for economic use.

Kisbiet mit-Tagħlim

It-Tmien Sena	
8.1	Kapaċi nuża ritratti mill-ajru, mapep, l-internet, mapep interattivi u <i>software</i> biex nillokalizza varjeta` ta' fatturi fiżiċi u umani importanti f'Malta, fil-Mediterran, fl-Ewropa u fid-dinja.
8.2	Kapaċi ninterpreta mappa li turi ż-żoni tal-ħin u niddeskrivi r-rabta bejn id-dawran tad-dinja u l-ħin.
8.3	Kapaċi nirriċerka każ (case study) biex niddeskrivi l-karatteristiċi u l-effetti ta' wieħed minn dawn id-diżastri naturali, bħall-uragani, l-għargħar, it-tsunami, in-nirien tal-foresti (wildfire), maltempati tar-ramel, il-valangi u l-maltempati tas-silġ (blizzard).
8.4	Kapaċi niddeskrivi fil-qosor il-kawża prinċipali taċ-ċaqliq tal-kontinenti u l-effetti fuq il-pajsaġġ, jiġifieri terremoti, vulkani u muntanji mmewġa.
8.5	Kapaċi nistharreġ każ (case study) ta' terremot u ta' vulkan biex niddeskrivi l-ħsara li jikkawunaw.
8.6	Nista' nagħti raġunijiet għaliex in-nies tgħix f'żoni tettonikament attivi u niddiskuti strategiji xierqa li bihom jistgħu jonqsu l-imwiet.
8.7	Kapaċi ngħaraf il-pajsaġġ u l-klima ta' deżert sħun u deżert kiesaħ kif ukoll insemmi xi adattazzjonijiet tal-veġetazzjoni u l-annimali biex jistgħu jgħixu f'dawn il-kundizzjonijiet.
8.8	Neżamina kif il-bniedem juża' d-deżerti sħan u/jew dawk kesħin għal skopijiet ekonomiċi.

Assessment Criteria

Learning Outcome	Assessment Criteria
<p>8.1 I can use aerial photos, maps, the internet, interactive maps and software to locate various key physical and human features of Malta, the Mediterranean, Europe and the wider world.</p>	<ul style="list-style-type: none"> • <i>This is a general outcome indicating the skills to be applied in pursuance of all outcomes.</i>
<p>8.2 I can interpret a map showing time zones and describe the connection between the Earth's rotation and time.</p>	<ul style="list-style-type: none"> • <i>Use a globe or online sources to demonstrate that the Earth makes a complete rotation in 24 hours.</i> • <i>Identify areas which are experiencing day and night on a diagram of a globe.</i> • <i>Interpret a 24-standard time zone map of the world.</i>
<p>8.3 I can research a case study to describe the characteristics and effects of any one of the following types of natural disasters such as hurricanes, flooding, tsunamis, wildfires, sandstorms, avalanches and blizzards.</p>	<ul style="list-style-type: none"> • <i>Define what a natural disaster is.</i> • <i>Give examples of different types of natural disasters.</i> • <i>Locate the area of the chosen natural disaster on a map.</i> • <i>Describe the natural disaster.</i> • <i>Describe the effects of the chosen natural disaster on people and the environment.</i>
<p>8.4 I can outline the main cause of plate movement and its main effects on the landscape, namely earthquakes, volcanoes and fold mountains.</p>	<ul style="list-style-type: none"> • <i>Label the four layers of the interior of the Earth.</i> • <i>Illustrate on a diagram and describe how convection currents move the Earth's tectonic plates.</i> • <i>Name the three effects of plate movements (earthquakes, volcanoes and fold mountains).</i> • <i>Locate three volcanoes, three fold mountains and three earthquake prone areas on a map of the world using an atlas and/or digital media.</i> • <i>Label a cross-section diagram of the interior structure of a volcano (crater, vent, layers of lava and ash, magma chamber).</i>

<p>8.5 I can research a case study of an earthquake and of a volcano to illustrate their effects.</p>	<p><i>Earthquake case study:</i></p> <ul style="list-style-type: none"> • <i>Locate the area hit by the earthquake on a map of the world and region.</i> • <i>Give the strength of the earthquake on the Richter scale.</i> • <i>Locate the epicentre of the earthquake.</i> • <i>List the effects of the earthquake.</i> <p><i>Volcano case study:</i></p> <ul style="list-style-type: none"> • <i>Locate the volcano on a map of the world and region.</i> • <i>State whether the volcano is extinct, dormant and active.</i> • <i>Describe the hazards associated with the volcanic eruption chosen.</i>
<p>8.6 I can give some reasons why people choose to live in tectonically active zones as well as describe safe behaviour during earthquakes.</p>	<ul style="list-style-type: none"> • <i>List the negative and positive aspects of living in tectonically active zones.</i> • <i>Demonstrate and relate safe behaviour during an earthquake simulation. (Drop, Cover and Hold procedure)</i>
<p>8.7 I can recognise the landscape and climate of a hot and a cold desert and list some adaptations of vegetation and animals to survive these environments.</p>	<ul style="list-style-type: none"> • <i>Define what a desert is.</i> • <i>Name and locate on a map of the world two hot and two cold deserts from around the world.</i> • <i>Recognise typical landscapes of hot and cold deserts.</i> • <i>Read a rainfall and temperature graph of a hot and a cold desert.</i> • <i>List common adaptations of vegetation and animals of a hot and a cold desert.</i>
<p>8.8 I can explore how people exploit hot and/or cold deserts for economic use.</p>	<ul style="list-style-type: none"> • <i>Explore a case study of one major economic project in a hot and/or cold desert. (e.g. Palm Jumeirah Island in Dubai; Sahara Forest Project in Jordan; Make the desert bloom – The Negev in Israel; oil drilling in the Gobi desert).</i>

Kriterji tal-Assessjar

Kisba mit-Tagħlim	Kriterji tal-Assessjar
<p>8.1 Kapaċi nuża ritratti mill-ajru, mapep, l-internet, mapep interattivi u “software” biex nillokalizza varjeta` ta’ fatturi fiżiċi u umani importanti f’Malta, fil-Mediterran, fl-Ewropa u fid-dinja.</p>	<ul style="list-style-type: none"> • <i>Din hija kisba mit-tagħlim ġenerali u għandha tintuża matul il-programm kollu biex permezz tagħha jintlaħqu il-kisbiet l-oħra.</i>
<p>8.2 Kapaċi ninterpretar mappa li turi ż-żoni tal-ħin u niddeskrivi r-rabta bejn id-dawran tad-dinja u l-ħin.</p>	<ul style="list-style-type: none"> • <i>Nuża globu jew sorsi diġitali biex nuri li d-dinja tiegħu 24 siegħa biex iddur dawra sħiħa (rotazzjoni) fuq il-fus tagħha.</i> • <i>Nagħraf postijiet li għandhom id-dawl (filgħodu) u oħrajn għandhom id-dlam (billejl) fuq il-globu.</i> • <i>Ninterpretar mappa tad-dinja li turi l-24 zona tal-ħin standard.</i>
<p>8.3 Kapaċi nirriċerka każ (case study) biex niddeskrivi l-karatteristiċi u l-effetti ta’ wieħed minn dawn id-diżastri naturali, bħall-uragani, l-għargħar, it-tsunami, in-nirien tal-foresti (wildfire), maltempati tar-ramel, il-valangi u l-maltempati tas-silġ (blizzard).</p>	<ul style="list-style-type: none"> • <i>Nispjega x’inhu diżastru naturali.</i> • <i>Nagħti eżempji ta’ tipi differenti ta’ diżastri naturali.</i> • <i>Nuri fuq mappa fejn seħħ id-diżastru naturali li għażilt.</i> • <i>Niddeskrivi d-diżastru naturali.</i> • <i>Niddeskrivi l-effetti tad-diżastru naturali li għażilt fuq in-nies u l-ambjent.</i>
<p>8.4 Kapaċi niddeskrivi fil-qosor il-kawża prinċipali taċ-ċaqliq tal-kontinenti u l-effetti fuq il-pajsaġġ, jiġifieri terremoti, vulkani u muntanji mmewġa.</p>	<ul style="list-style-type: none"> • <i>Nillejbilja l-erba’ saffi interni tad-dinja.</i> • <i>Nuri fuq disinni u niddeskrivi kif il-kurrenti konvezzjonali jcaqalqu l-qxur tettoniċi tad-dinja.</i> • <i>Insemmi t-tliet effetti taċ-ċaqliq tal-qxur tettoniċi (terremoti, vulkani u muntanji mmewġa).</i> • <i>Nuri tliet vulkani, tliet muntanji mmewġa u tlett inħawi li jintlaqtu ta’ spiss mit-terremoti fuq mappa tad-dinja billi nuża atlas jew media diġitali.</i>

	<ul style="list-style-type: none"> • <i>Nillebilja disinn (cross-section) tal-istruttura interna ta' vulkan (bokka, arterja vulkanika, saffi ta' rmied u lava, ħawt tal-magma).</i>
<p>8.5 Kapaċi nistħarreg każ (case study) ta' terremot u ta' vulkan biex nispjega l-ħsara li jikkagunaw.</p>	<p><i>Każ ta' terremot:</i></p> <ul style="list-style-type: none"> • <i>Nuri fejn jinsab il-post li ntlaqat mit-terremot fuq mappa tad-dinja u tar-reġjun.</i> • <i>Nagħti l-qawwa tat-terremot fuq l-iskala Richter.</i> • <i>Nimmarka l-epicentru tat-terremot fuq mappa.</i> • <i>Insemmi l-ħsara tat-terremot.</i> <p><i>Każ ta' vulkan:</i></p> <ul style="list-style-type: none"> • <i>Nuri fejn jinsab il-vulkan fuq mappa tad-dinja u tar-reġjun.</i> • <i>Nagħraf jekk il-vulkan hux estint (mejjet), inattiv (rieqed) jew attiv (ħaj).</i> • <i>Niddeskrivi l-perikli marbuta mal-iżbroff tal-vulkan magħżul.</i>
<p>8.6 Nista' nagħti raġunijiet għaliex in-nies tgħix f'żoni tettonikament attivi u niddeskrivi x'għandi nagħmel waqt terremot.</p>	<ul style="list-style-type: none"> • <i>Insemmi aspetti negattivi u oħrajn pożittivi li tkun tgħix f'żoni tettonikament attivi.</i> • <i>Nuri li naf x'għandi nagħmel f'eżerċizzju ta' emerġenza relatat ma' terremot. (Il-proċedura ta' Drop, Cover and Hold).</i>
<p>8.7 Kapaċi ngħaraf il-pajsaġġ u l-klima ta' deżert sħun u deżert kiesaħ kif ukoll insemmi xi adattazzjonijiet tal-veġetazzjoni u l-animali biex jistgħu jgħixu f'dawn il-kundizzjonijiet</p>	<ul style="list-style-type: none"> • <i>Niddefinixxi x'inhu deżert.</i> • <i>Insemmi u nimmarka fuq mappa tad-dinja żewġ deżerti sħan u żewġ deżerti keshin minn madwar id-dinja.</i> • <i>Nagħraf il-pajsaġġ tipiku ta' deżerti sħan u keshin.</i> • <i>Naqra graff tax-xita u tat-temperatura ta' deżert sħun u deżert kiesaħ.</i> • <i>Insemmi xi adattazzjonijiet komuni tal-veġetazzjoni naturali u l-animali li permezz tagħhom ikunu jistgħu jgħixu fid-deżerti sħan u keshin.</i>
<p>8.8 Nezamina kif il-bniedem juża' d-deżerti sħan u/jew dawk keshin għal skopijiet ekonomiċi.</p>	<ul style="list-style-type: none"> • <i>Nistħarreg każ (case study) ta' proġett ekonomiku kbir li seħħ f'deżert sħun u/jew deżert kiesaħ (e.g. Palm Jumeirah Island f'Dubai, Sahara Forest Project fil-Ġordan, Inħaddru d-deżert tan-Negev fl-Iżrael; tħaffir għaż-żejt fid-deżert Gobi).</i>

Learning outcomes are student-centred in that they focus on the knowledge and skills that will be most valuable to the student now and in the future. As a result, schools may wish to adapt this outcome-based syllabus to meet the needs of students with learning difficulties or with challenging behaviour. In this case teachers may opt to concentrate on certain learning outcomes. Assessment for an adapted syllabus should be based 100% on a variety of school-based tasks. The more varied the tasks, the greater is the validity of the whole assessment exercise.

If a school decides to have a year 7 CCP (Core Curriculum Programme) syllabus in geography the administration is to seek approval from the director DLAP. Following consultation with the education officer and the heads of the department the school will then be able to amend the syllabus to address their students' needs and abilities. The EAU must also be informed. Students following a CCP geography syllabus are to be assessed through a variety of tasks spread out throughout the year. Students following such an adapted syllabus will be exempted from the end of year examination set by the Directorate for Learning and Assessment Programmes.

Scheme of Assessment

The examination consists of:

Summative assessment: (60% of the total marks; comprising of a one hour written exam) set at the end of the scholastic year.

School-based assessment: (40% of the total marks; comprising of **two** tasks of equal weighting i.e. 20% each) set during the scholastic year.

Summative assessment: (60% of the total mark)

The controlled component of the assessment will consist of a paper of one-hour duration carrying 60% of the final mark and set by the Directorate for Learning and Assessment Programmes. There will be two versions of the paper, one in English and one in Maltese. Schools are to indicate the number of papers required in either language. The examination will carry 100 marks and questions will be set on all Learning Outcomes.

Questions will be structured with gradients of difficulty including objective questions (e.g. completion, true/false, multiple choice questions, cloze questions) resource based questions involving data response and problem solving as well as free response writing. The questions set will assess the students' understanding and application of the main geographical concepts and knowledge, the acquisition of basic geographical skills and the development of attitudes and values as required in the Learning Programme. Candidates will be required to answer all questions.

School-Based Assessment (40% of the total mark)

Each school-based assignment is marked out of 20 marks and will carry 20% of the total mark. The average mark of these two assignments will contribute to 40% of the total marks of the examination. It is recommended that a significant proportion of SBA will be done in class under direct teacher supervision. These assignments will be set and marked by the teacher.

Learning outcomes are student-centred in that they focus on the knowledge and skills that will be most valuable to the student now and in the future. As a result, schools may wish to adapt this outcome-based syllabus to meet the needs of students with learning difficulties or with challenging behaviour. In this case teachers may opt to concentrate on certain learning outcomes. Assessment for an adapted syllabus should be based 100% on a variety of school-based tasks. The more varied the tasks, the greater is the validity of the whole assessment exercise. Students following such an adapted syllabus will be exempted from the end of year examination set by the Directorate for Learning and Assessment Programmes.

Teachers can choose any **TWO** tasks from the following:

TASK 1	Learning Outcome 8.1 I can use aerial photos, maps, the internet, interactive maps and software to locate various key physical and human features of Malta, the Mediterranean, Europe and the wider world.
20 marks Assessed by the teacher Externally moderated 20% of total marks	Students will use resources such as atlases, globes, maps and the internet to locate a number of countries/cities, continents, bodies of water etc. on a world map. Students are to locate countries on a large (A3) blank outline map of the world. They can use different resources to discover the continent where each country is found and its capital city. Students can also calculate the distance of countries from Malta. Students need to: <ul style="list-style-type: none">• list at least 8 countries, with at least one from each continent and including the Maltese Islands that the students have heard about on the media;• locate and label these 8 countries on a large A3 blank outline map of the world;• find the capital city of these 8 countries;• locate and label the mother country or a country they would like to visit;• discover in which continent each country is found;• name a landlocked country and a country that borders with a sea or ocean;• mention a country or body of water that borders these countries. An example of such a task including its marking scheme is available in the appendix.

TASK 2	<p>Learning Outcome 8.3</p> <p>I can research a case study to describe the characteristics and effects of any one of the following types of natural disasters such as hurricanes, flooding, tsunami, wildfires, sandstorms, avalanches and blizzards.</p>
<p>20 marks</p> <p>Assessed by the teacher</p> <p>Externally moderated</p> <p>20% of total marks</p>	<p>Students will name and locate on a map a natural disaster. They describe the effects of the natural disaster on people and the environment. Students can present their work in a range of texts such as an illustrated essay, brochure, flyer, letter, journal or newspaper article. Students need to:</p> <ul style="list-style-type: none"> • name the natural disaster; • locate the disaster area on a world map and on a regional map; • include the places affected; • describe briefly what happened during this natural disaster; • report when it happened and how long did it last; • include captioned images of the problems caused; • describe the effects on people and the environment.

TASK 3	<p>Learning Outcome 8.4</p> <p>I can outline the main cause of plate movements and its main effects on the landscape, namely earthquakes, volcanoes and fold mountains.</p>
<p>20 marks</p> <p>Assessed by the teacher</p> <p>Externally moderated</p> <p>20% of total marks</p>	<p>Students will explain with the help of diagrams the cause of plate movement and its effects. Students will research the internet to obtain locations of recent earthquakes and volcanic eruptions. They can use the USGS website (which provides a list of earthquakes for the past 30 days) and Global Volcanism Site (which shows the location of volcanoes). Students need to:</p> <ul style="list-style-type: none"> • label the four layers of the interior of the earth on a diagram; • clearly label the convection currents on the diagram; • add a brief description to explain how the earth's crust is constantly shifting due to convection currents in the mantle; • name the three effects of plate movements (earthquakes, volcanoes and fold mountains); • locate, by creating a key, three volcanoes, three fold mountain ranges and three earthquake prone areas on a large outline map of the world; • use digital media to locate on a map at least three earthquakes that struck in the last 30 days with a magnitude higher than 4 on the Richter Scale. They can add to the map the date when each earthquake struck; • use digital media to locate on a map at least three volcanoes that erupted recently.

TASK 4	<p>Learning Outcome 8.5</p> <p>I can research a case study of an earthquake and of a volcano to illustrate their effects.</p>
<p>20 marks</p> <p>Assessed by the teacher</p> <p>Externally moderated</p> <p>20% of total marks</p>	<p>Students will conduct research from books and/or the internet about one volcano from around the world. They need to obtain information about the location and state (active, dormant, extinct) of the chosen volcano and damage caused. Students needs to:</p> <ul style="list-style-type: none"> • locate and label the volcano under study on a world map; • show where the volcano is found on a country/region map; • state the date and duration of an eruption; • give the state of the volcano (active, dormant, extinct); • describe what happened during the volcanic eruption (explosion, lava, ash); • briefly describe the damage done during the eruption to people and the environment; • include captioned images of the damage done during the eruption to people and the environment. <p>An example of such a task including its marking scheme is available in the appendix.</p>

TASK 5	<p>Learning Outcome 8.5</p> <ul style="list-style-type: none"> • I can research a case study of an earthquake and of a volcano to illustrate their effects.
<p>20 marks</p> <p>Assessed by the teacher</p> <p>Externally moderated</p> <p>20% of total marks</p>	<p>For this school-based assessment students need to access the Reusable Learning Objects (RLOs) which are available online via the iLearn Virtual Learning Environment (VLE). Students need to complete the RLO entitled:</p> <ul style="list-style-type: none"> • The Effects of Earthquakes in the Mediterranean Region <p>Through this digital resource students can locate seismic activity in the Mediterranean, describe and explain the effects of earthquakes and how these are measured on the Richter Scale. Students need to present a print out of the RLO, namely <i>The Effects of Earthquakes in the Mediterranean Region</i>.</p>

<p>TASK 6</p>	<p>Learning outcome 8.7 I can recognise the landscape and climate of a hot and a cold desert and list some adaptations of vegetation and animals to survive these environments.</p>
<p>20 marks</p> <p>Assessed by the teacher</p> <p>Externally moderated</p> <p>20% of total marks</p>	<p>Students need to locate at least two hot and two cold deserts on a map of the world and describe the climatic conditions and list adaptations of plants and animals in these deserts. Students can present their work using charts, as a portfolio of work, through a newspaper report, brochure or any other format.</p> <p>Students need to:</p> <ul style="list-style-type: none"> • locate on a map and name at least two hot and two cold deserts; • name countries/continents which are covered or partly covered by the chosen hot and cold deserts; • present captioned images of the hot and cold deserts chosen; • describe the rainfall pattern in a hot and in a cold desert by reading rainfall graphs; • describe the temperature pattern in a hot and in a cold desert by reading temperature graphs; • present captioned images of plants and animals that live in hot and cold deserts; • describe how plants and animals are able to survive in such hostile conditions.

Marking Criteria

	1 - 6 marks	7 – 12 marks	13 – 20 marks
SBA 1 Knowing the World	<ul style="list-style-type: none"> Overall appearance of the map is poor with most requirements missing. Only a few places are marked and labelled correctly. Presentation is poor. Lacks most of the requirements of the course work. . 	<ul style="list-style-type: none"> Overall appearance of the map is satisfactory. Some places are not located or labelled accurately. Meets some of the requirements of the course work. Presentation is basic. 	<ul style="list-style-type: none"> Places are accurately marked and neatly labelled on the map. Meets most of the requirements of the course work. Presentation is excellent.
SBA 2 Case Study: Natural Disaster	<ul style="list-style-type: none"> Maps indicating location of the disaster area have a lot of inaccuracies. Images presented lack accuracy, neatness and clarity with most labels missing. Makes limited use of terminology and brief statements to describe the damage caused by the natural disaster. Lacks most of the requirements of the course work. Presentation is poor. 	<ul style="list-style-type: none"> Maps indicating the location of the disaster area are partly accurate. Appropriate images are included but not well captioned. Uses some terminology that is appropriate to describe the damage caused by the natural disaster. Meets some of the requirements of the course work. Presentation is basic. 	<ul style="list-style-type: none"> Maps indicating the location of the disaster area are accurate. Images are appropriate and well captioned. Uses terminology accurately to describe the damage caused by the natural disaster. Meets all or most of the requirements of the course work. Presentation is excellent.
SBA 3 Main cause of plate movement and its effects.	<ul style="list-style-type: none"> Diagram is inaccurate and most labels are missing or inaccurate. Map requested by coursework contains a lot of inaccuracies. 	<ul style="list-style-type: none"> Diagram lacks accuracy and some labels are missing or inaccurate. Map lacks accuracy in the location of the features requested in the coursework. 	<ul style="list-style-type: none"> Diagram is accurate and clearly labelled. Map accurately shows the location of the features requested in the coursework.

	<ul style="list-style-type: none"> • The key is either missing or does not distinguish the features included on the map. • Makes limited use of terminology to describe the causes and effects of plate movements on the landscape. • Lacks most of the requirements of the course work. • Presentation is poor. 	<ul style="list-style-type: none"> • The key distinguishes only some of the features included on the map. • Uses some terminology to describe the causes and effects of plate movements on the landscape. • Meets some of the requirements of the course work. • Presentation is basic. 	<ul style="list-style-type: none"> • The key distinguishes clearly the features marked on the map. • Uses terminology accurately to describe the causes and effects of plate movements on the landscape. • Meets all the requirements of the course work. • Presentation is excellent.
SBA 4 Case Study: Volcanic Activity	<ul style="list-style-type: none"> • Maps indicating location of the volcano have a lot of inaccuracies. • Makes limited use of terminology to describe the damage caused by the volcanic eruption. • Images are not included or not captioned. • Lacks most of the requirements of the course work. • Presentation is poor. 	<ul style="list-style-type: none"> • Maps indicating the location of the volcano under study are partly accurate. • Uses some terminology to describe the damage caused by the volcanic eruption. • Images are included but not well captioned. • Meets some of the requirements of the course work. • Presentation is basic. 	<ul style="list-style-type: none"> • Maps indicating the location of the volcano under study are accurate. • Uses terminology accurately to describe the damage caused by a volcanic eruption. • Images are appropriate and well captioned. • Meets all the requirements of the course work. • Presentation is excellent.
SBA 5 Earthquakes (RLO)	<ul style="list-style-type: none"> • Accessed and presented a print out of the RLOs, namely, <i>The Effects of Earthquakes</i>. • Obtained between 1% and 30% of the total marks. 	<ul style="list-style-type: none"> • Accessed and presented a print out of the RLO, namely, <i>The Effects of Earthquakes</i>. • Obtained between 31% and 60% of the total marks. 	<ul style="list-style-type: none"> • Accessed and presented a print out of the RLO, namely, <i>The Effects of Earthquakes</i>. • Obtained over 61% of the total marks.
SBA 6 Hot and Cold Deserts	<ul style="list-style-type: none"> • Map indicating the location of hot and cold deserts has a lot of inaccuracies. • Interpretation of the two graphs is inaccurate. 	<ul style="list-style-type: none"> • Map indicating the location of hot and cold deserts is partly accurate. • Interpretation of the graphs is limited to descriptive sentences. 	<ul style="list-style-type: none"> • Map indicating the location of hot and cold deserts is accurate. • Accurate interpretation of the graphs.

	<ul style="list-style-type: none"> • Makes limited use of terminology to describe the adaptations of plants and animals. • Lacks most of the requirements of the course work. • Presentation is poor. 	<ul style="list-style-type: none"> • Uses some terminology to describe the adaptations of animals and plants. • Images are included but not well captioned. • Meets some of the requirements of the course work. • Presentation is basic. 	<ul style="list-style-type: none"> • Uses terminology accurately to describe the adaptations of animals and plants. • Images are appropriate and well captioned. • Meets all the requirements of the course work. • Presentation is excellent.
--	--	---	--

Reporting to parents/guardians

A digital reporting system will be used to report the progress of students to parents/guardians. List of students in each class and learning outcomes for that particular year will be available on the digital platform. The ticking of broad learning outcomes according to the achievement of the students for work conducted in class and/or at home, will provide students and parents with more information about the progress achieved during the scholastic year. It is expected that this information will support further learning and raise the engagement and achievement levels of the students. Evidence of written tasks will be found in the students' copybooks, school files or other students' materials.

A five-point Likert scale is used to measure if students have mastered or not each learning outcome of the learning and assessment programme. These include:

- Not achieved (**NT**)
- Partially achieved (**PA**)
- Satisfactorily achieved (**SA**)
- Fully achieved (**FA**)
- Not applicable (**NA**)

Teachers need to choose and mark one of the five options available for each student over the course of the scholastic year. The learning outcomes that are going to be assessed and reported include:

YEAR 8	
1	I can use aerial photos, maps, the internet, interactive maps and software to locate various key physical and human features of Malta, the Mediterranean, Europe and the wider world.
2	I can interpret a map showing time zones and describe the connection between the Earth's rotation and time.
3	I can research a case study to describe the characteristics and effects of any one of the following types of natural disasters such as hurricanes, flooding, tsunami, wildfires, sandstorms, avalanches and blizzards.
4	I can describe continental drift and its main effects, research a case study of an earthquake and of a volcano, give some reasons why people choose to live in tectonic zones and discuss appropriate strategies to save lives.
5	I can compare the landscape and climate of a hot and a cold desert and the adaptations of vegetation, animals and people to survive this environment and explore how people exploit deserts for economic use.

To be able to tick the broad learning outcomes of the year/subject, teachers are kindly asked to view the online video tutorials containing step by step content through the links available as follows: <https://vimeo.com/298128409>

List of Geographical terms – English to Maltese

Year 8

active volcano	vulkan ħaj/attiv
adaptation	adattazzjoni
African plate	il-qoxra Afrikana
Antarctica	Antartika
Arabian desert	id-deżert tal-Arabja
Atacama desert	id-deżert ta' Atacama
Australian desert	id-deżert tal-Awstralja
avalanches	valangi
blizzards	maltempati tas-silġ
Californian desert	id-deżert ta' Kalifornja
cold desert	deżert kiesaħ
continental drift	lċ-ċaqliq tal-kontinenti
convection currents	kurrenti konvezzjonali
crater	bokka
crust	qoxra tad-dinja
dormant volcano	vulkan rieqed/inattiv
earthquake	terremot
environment	ambjent
epicentre	epiċentru tat-terremot
Eurasian plate	il-qoxra Ewroasjatika
extinct volcano	vulkan mejjet/estint
flooding	għargħar
fold mountains	muntanji mmewġa
frost bite	infjammazzjoni tal-ġilda bil-ksieħ <i>'frostbite'</i>

geothermal energy	enerġija ġeotermali
geyser	<i>geyser</i>
Gobi desert	id-deżert Gobi
Greenwich meridian	il-Meridjan ta' Greenwich
heat stroke	xemxata
hot desert	deżert sħun
hurricane	uragan
igneous rock	blat ignijuż
inner core	qalba ta' ġewwa
Kalahari desert	id-deżert ta' Kalahari
landscape	pajsagġ
lava flow	nixxieġha tal-lava
layers of lava and ash	saffi ta' rmied u lava
longitude	longitudni
magma chamber	ħawt tal-magma
mantle	mantell tad-dinja
natural disaster	dizastri natural
oasis	oasi
outer core	qalba ta' barra
Patagonian desert	id-deżert ta' Patagonja
physical map	mappa fiżika
plate boundary/margin	xifer tettoniku (pl. xfar)
pyroclastic flow	daħna piroklastika
rainfall graph	graff tax-xita
range of mountains	katina ta' muntanji
Richter scale	l-iskala Richter

rock pedestall	pedestall tal-blat
rocky desert	deżert blati
rotation of the Earth	id-dawran tad-dinja
Sahara desert	id-deżert tas-Saħara
sand dune	għarma ramel (pl. għaram tar-ramel)
sandstorm	maltempati tar-ramel
sandy desert	deżert ramli
tectonic hazards	perikli tettoniċi
tectonic plates	il-qxur tettoniċi
temperature graph	graff tat-temperatura
thermal mud	tajn termali
thermal spring	fawwara termali
time zone map	mappa li turi ż-żoni tal-ħin
tsunami	tsunami
vent	arterja vulkanika
volcanic bomb	xrar u biċċiet ta' blat vulkaniku
volcanic eruption	żbroffa ta' vulkan
volcano	vulkan
wildfires	nirien tal-foresti

Appendices

It-8 Sena

Mudell
Assessjar Kontinwu

Ġeografija

Kisba mit-tagħlim

Kapaċi nistħarreg każ (case study) ta' terremot u ta' vulkan biex nispjega l-ħsara kbira li jikkagunaw.

Kapaċi nuża ritratti mill-ajru, mapep, l-internet, mapep interattivi u *software* biex nillokalizza varjeta` ta' fatturi fiżiċi u umani importanti f' Malta, fil-Mediterran, fl-Ewropa u fid-dinja.

Isem tal-istudent

Klassi

Żbroff tal-vulkan Anak Krakatau

Bl-għajnuna ta' dan il-*video* qasir li juri l-ħsara li jagħmel vulkan meta jżbroffa, wieġeb dawn il-mistoqsijiet .

Ara dan il-*video* dwar l-iżbroff tal-vulkan Anak Krakatau fl-2018. (Agħfas fuq ir-ritratt)



1. (a) Fil-*video* rajna iżbroff tal-vulkan Anak Krakatau fl-2018. Dan il-vulkan huwa **ħaj**, **rieqed** jew **mejjet**?

Il-vulkan Anak Krakatau huwa vulkan

(1)

(b) Għaliex taħseb hekk?

.....
.....
.....

(1)

2. Fuq din il-mappa tan-naħa t'isfel tal-Asja immarka fejn jinsab il-vulkan Anau Krakatau.

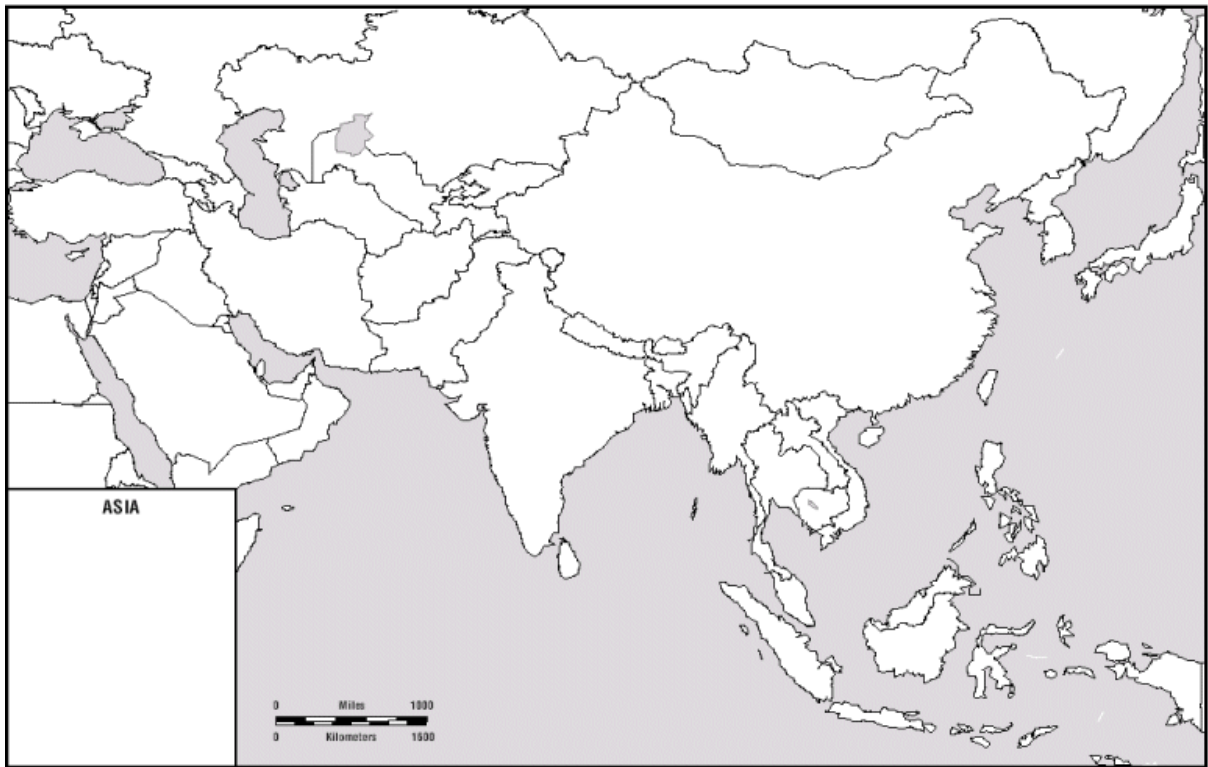

(1)

3. Fuq il-mappa tal-Indonesja uri fejn jinsab il-vulkan Anau Krakatau.

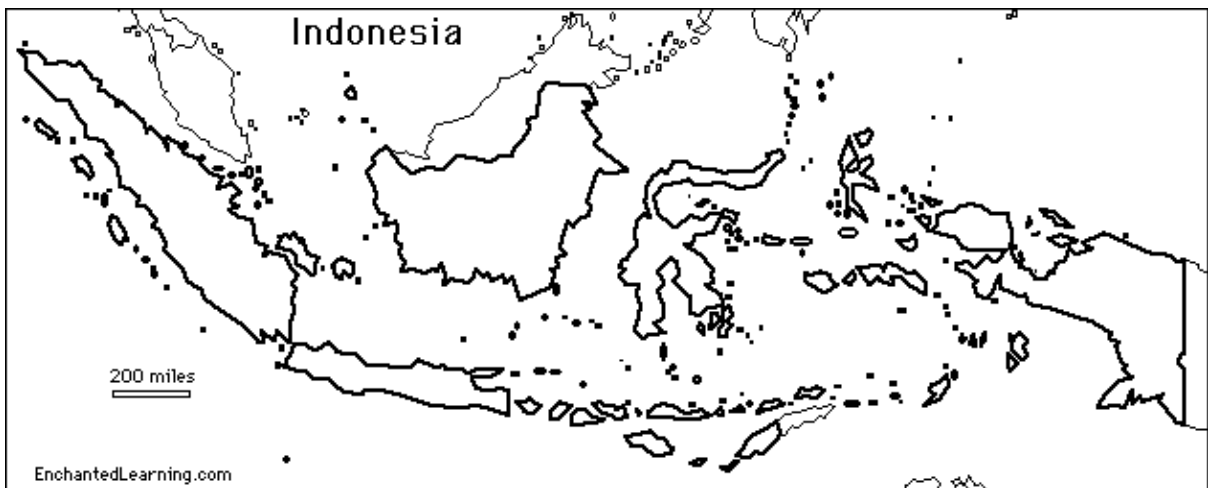

(1)

4. Spjega fil-qosor x'iwassal biex jiżbroffa vulkan.

.....
.....

(2)

5. Meta seħħ u kemm dam għaddej dan l-iżbroff?

.....

(2)

6. Iddeskrivi fil-qosor x'għara waqt l-iżbroff tal-vulkan Anau Krakatau.

.....

.....

.....

.....

.....

(4)

7. Sib stampi li juru l-attività' vulkanika tal-vulkan Anau Krakatau u xi effetti tal-vulkan.

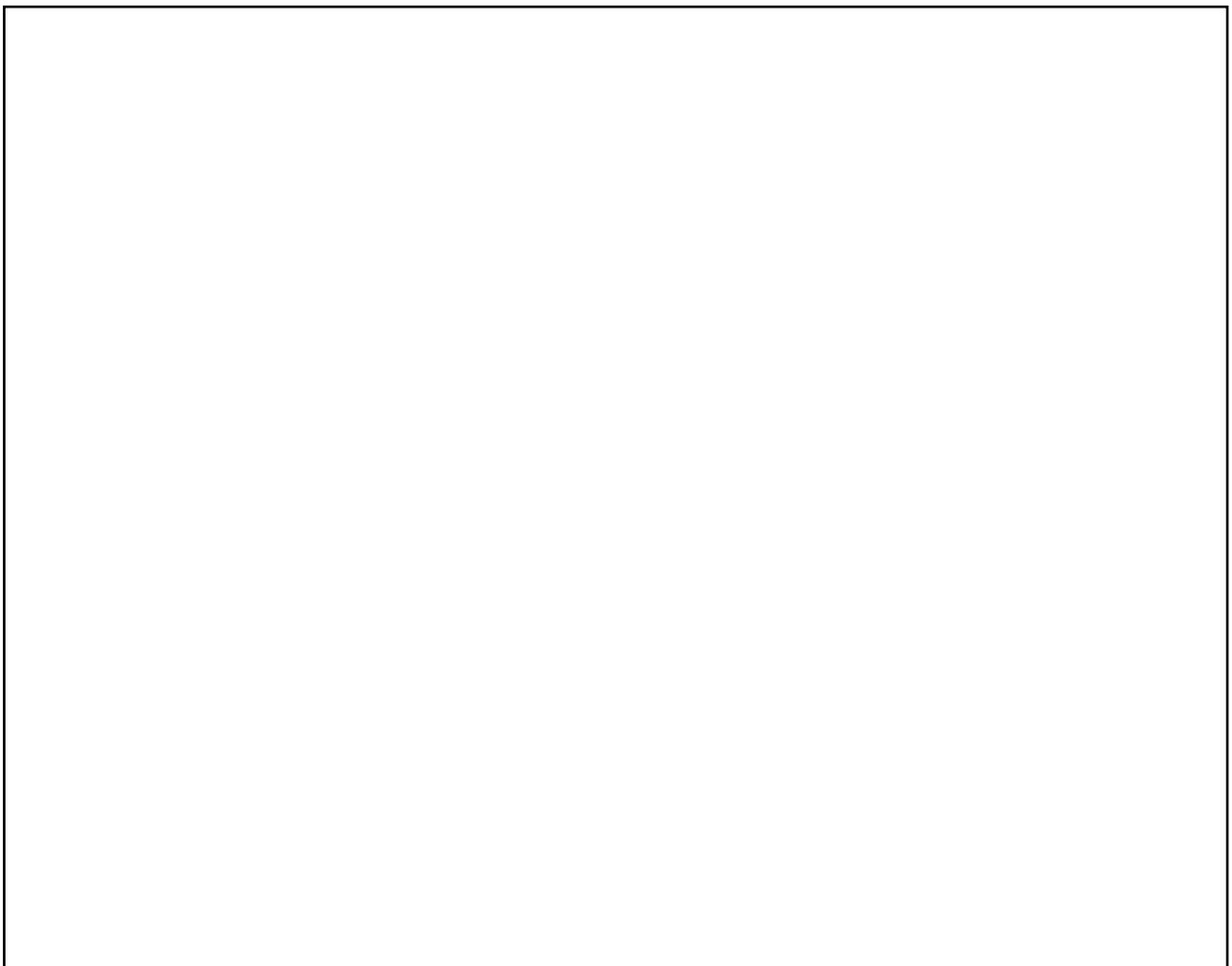

(2)

8. X'kienu l-effetti tal-izbroff fuq in-nies li jgħixu madwar il-vulkan Anau Krakatau?

.....

.....

.....

.....

.....

(3)

9. X'kienu l-effetti tal-izbroff fuq l-ambjent madwar il-vulkan Anau Krakatau?

.....

.....

.....

.....

.....

(3)

YEAR 8

Sample
School-Based Assessment

Geography

Learning Outcome

I can use aerial photos, maps, the internet, interactive maps and software to locate various key physical and human features of Malta, the Mediterranean, Europe and the wider world.

Name of student

Class

All around the world.

Use resources such as an atlas, a globe and the internet to locate some countries on a world map. This will help you improve your spatial geographical knowledge.

1. List eight countries that you heard about on the media. Include at least one country from each continent.

.....

.....

2. Use an atlas, a globe or google earth to locate all the eight countries you named in question one. Colour and label each country on the large (A3) blank outline map of the world.

(4)

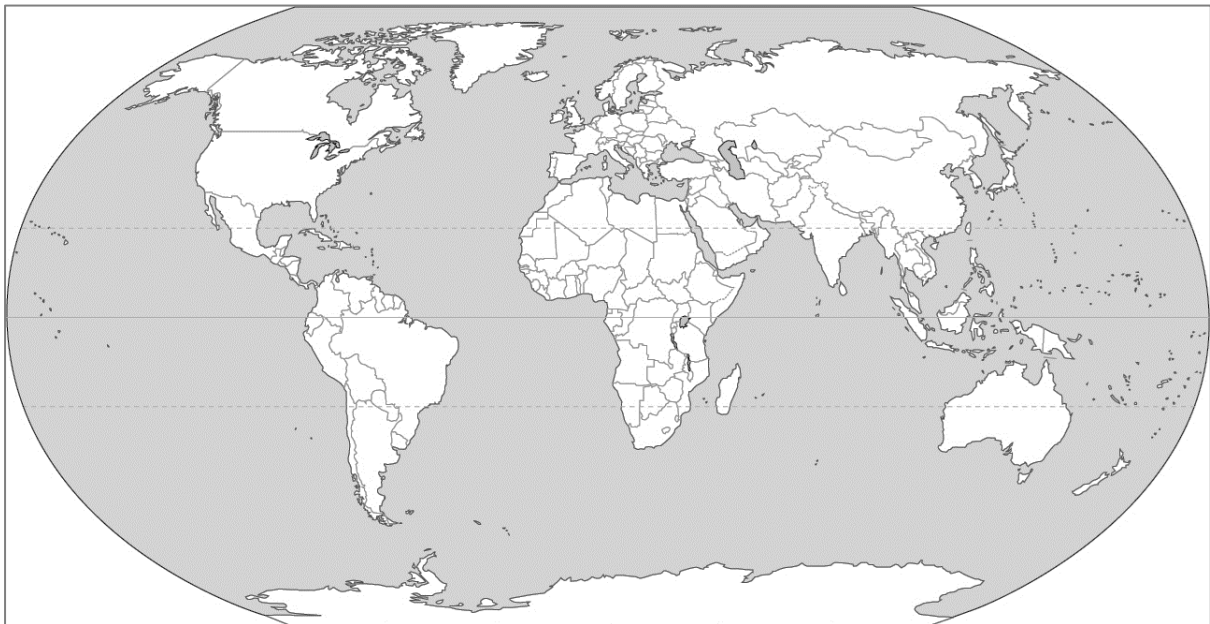

3. Locate and label the Maltese Islands on the map.

(1)

4. On the map itself, colour and label the country where you were born or a country you would like to visit.

(1)

5. Choose one landlocked country and name a country that borders with it.

Landlocked country	Bordering country

(1)

6. Choose a country that is bordered by a sea or ocean and name the sea or ocean that borders with it.

Country bordered by the sea	Bordering country

(1)

7. Use an atlas, a globe or google earth to discover in which continent each of the eight countries listed in question 1 belong. Write each country under the proper column.

Europe	Africa	North America	South America	Asia	Oceania (Australia)

(4)

8. Write the name of the capital city of each of the eight countries you mentioned in question 1.

Country	Capital City

(4)

9. Locate and label these capital cities on your map of the world.

(4)

L-Eżamijiet Annwali tal-Iskejjel Sekondarji

Karta Mudell

It-Tmien Sena

ĠEOGRAFIJA

HIN: Siegħa

Isem: _____ **Klassi:** _____

Wieġeb il-mistoqsijiet kollha.

Taħriġ 1

Disinn 1 juri mappa tal-Amerka ta' Fuq.

Wieġeb dawn il-mistoqsijiet.

- a. Ma' liema pajjiżi tmiss l-Istati Uniti?
..... (2)
- b. F'liema pajjiż tinsab il-belt ta' San Francisco?
..... (1)
- c. X'jismu l-oċean l-aktar viċin tal-belt ta' Washington DC?
..... (1)
- d. X'jisimhom l-għadajjar li jinsabu bejn l-Istati Uniti u l-Kanada?
..... (1)
- e. F'liema oċean jinsabu ħafna mill-gzejjer tal-Kanada?
..... (1)
- f. Liema pajjiżi m'għandhomx il-kosta ta' għom tmiss mal-Golf tal-Messiku?
(Aghzel minn: il-Messiku, il-Kanada, l-Istati Uniti, Greenland, il-Gwatemala).
..... (3)
- g. Ma' liema pajjiż ta' għmel l-Alaska?
..... (1)



Disinn 1 – Mappa tal-Amerka ta' Fuq

Taħriġ 2

Disinn 2 juri mappa tad-dinja biż-żoni tal-ħin.

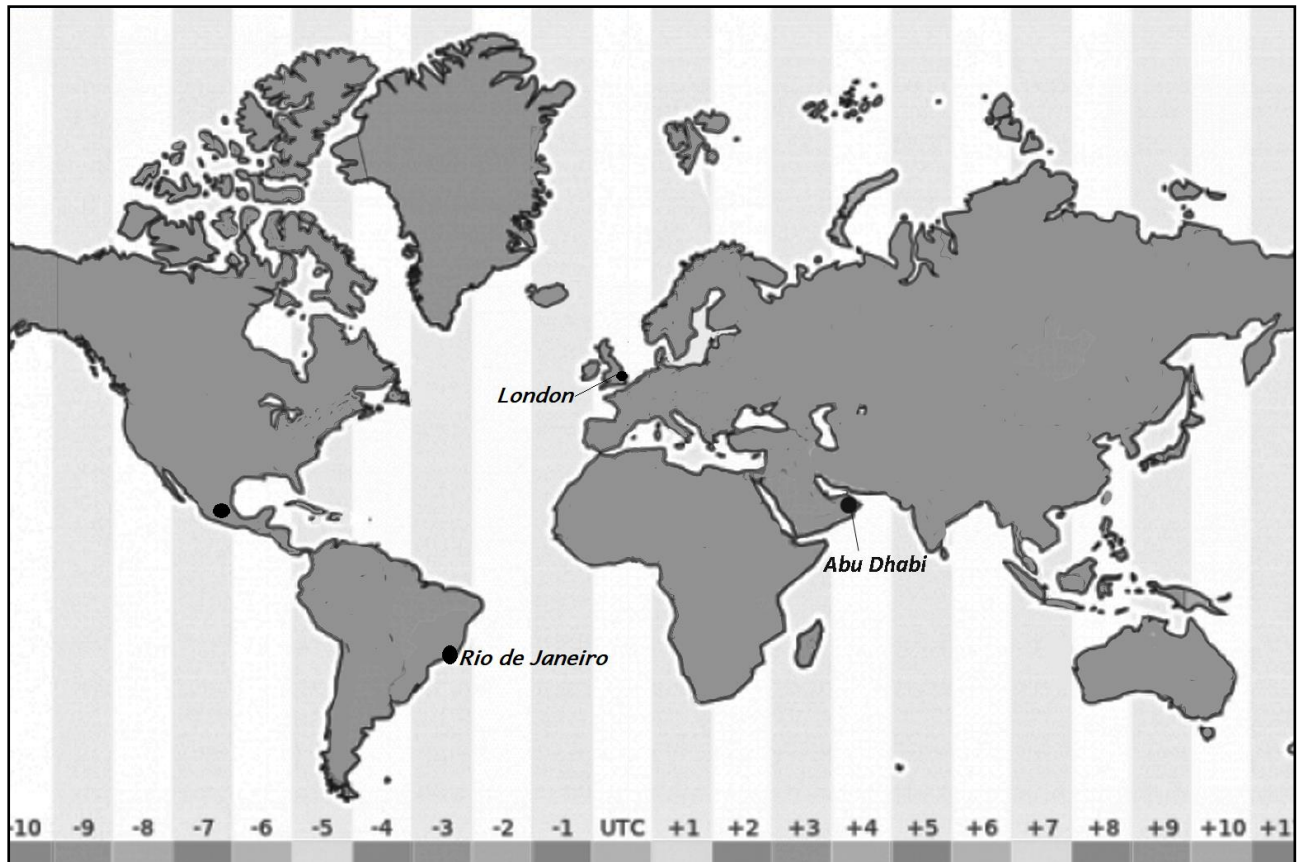

a. F'Londra il-ħin huwa it-8 ta' filgħodu (8:00). X'inhu l-ħin

f'Rio de Janeiro? _____

f'Abu Dhabi? _____

f'Malta? _____

(6)

Stephen li joqgħod in-Naxxar, huwa dilettant kbir tat-tlielaq tal-karozzi tal-Formula 1. Fittex fuq l-Internet u sab li t-tigrija li jmiss ser issir f'Abu Dhabi. Sab ukoll li t-tigrija se tibda fil-5:00 ta' wara nofsinhar (17:00) ħin ta' Abu Dhabi. Ftit qabel il-5:00 ta' wara nofsinhar ħin ta' Malta Stephen xegħel it-televixin iżda b'dizappunt kbir sab li t-tigrija kienet spiccat. Għalhekk Stephen ikkonkluda li l-informazzjoni li sab fuq l-internet kienet hażina.

b. Taħseb li l-konklużjoni ta' Stephen hija korretta? (Ittikkja ✓ l-kaxxa t-tajba)

Iva

Le

(1)

c. Agħti raġuni għat-twegiba tiegħek.

.....(3)

Taħriġ 3

Disinn 3 juri xi diżastri naturali li jseħħu fid-dinja minn żmien għall-iehor.

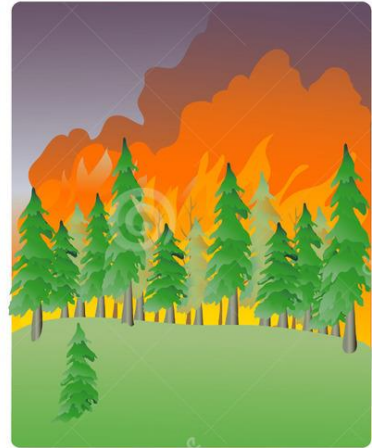
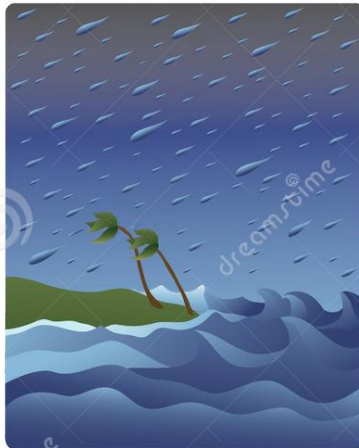

Disinn 3 – Diżastri Naturali

a. Bl-għajjnuna ta' disinn 3 spjega x'inhu diżastru naturali.

.....
.....
.....

(2)

b. Agħti **ERBA'** eżempji ta' diżastri naturali. (Tista' ssemmi oħrajn li ma jidhrux fl-istampi).

.....
.....

(4)

- c. Ikteb paragrafu dwar diżastru naturali li studjat dwaru. Iddeskrivi d-diżastru naturali, għid fejn seħħ u xi ħsara għamel.

Id-diżastru naturali li se nikteb dwaru hu:

.....

.....

.....

.....

.....

.....

.....

.....

.....

(8)

Taħriġ 4

Disinn 4 juri l-istruttura tad-dinja minn ġewwa.

- a. Illejbilja disinn 4 b'dawn il-kliem:

il-qalba ta' barra il-qalba ta' ġewwa il-qoxra tad-dinja il-mantell

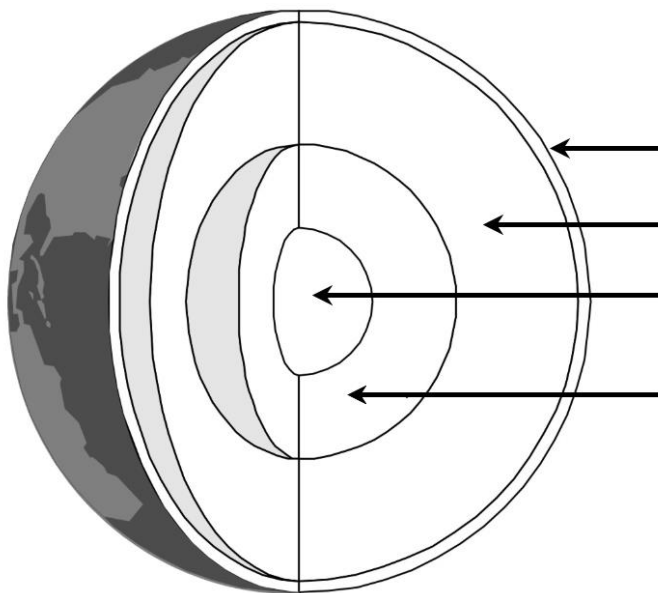

Disinn 4 – L-istruttura tad-dinja minn ġewwa

(4)

b. Fuq **disinn 4** immarka l-kurrenti konvezzjonali. (2)

c. X'qiegħed joħloq il-kurrenti ċirkolari?
.....
..... (2)

d. X'jigri meta l-kurrenti konvezzjonali jaħbtu mal-qoxra tad-dinja?
.....
..... (2)

e. **Disinn 5** juri vulkan kif ikun minn ġewwa. Illejbilja dawn li ġejjin fuq id-disinn stess.

nixxieġha tal-lava	ħawt tal-magma	irmied
saffi ta' lava u rmied	arterja vulkanika	bokka

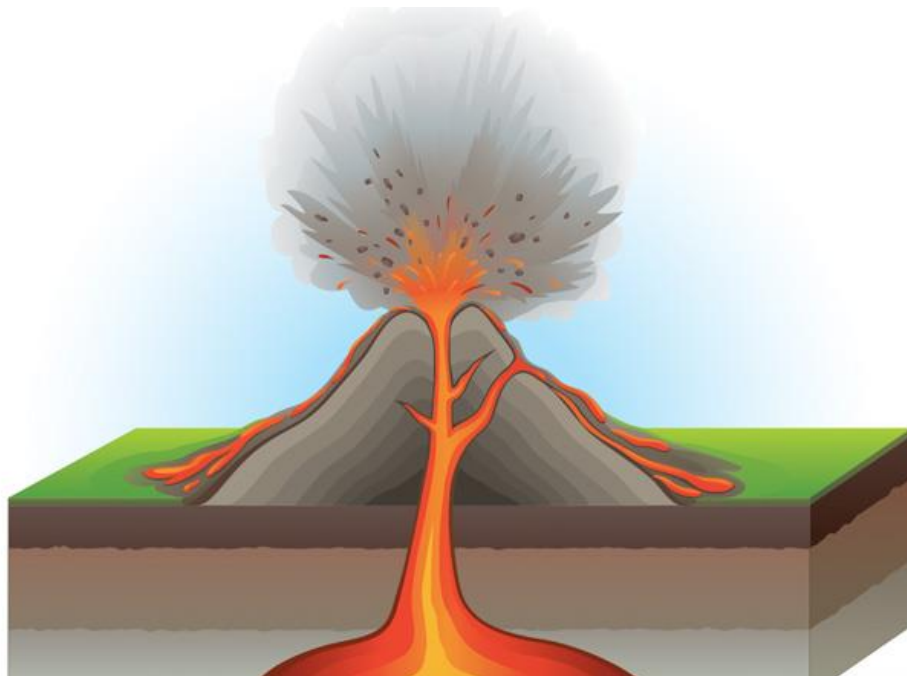

Disinn 5 – L-istruttura ta' vulkan minn ġewwa

(6)

- f. X'jista' jìgri meta l-qxur tettoniçi jicçaqalqu. Ittikja (✓) it-twegibiet it-tajba biss.

Jizbroffa xi vulkan.	
Tagħmel ħafna xita f'salt.	
Jiffurmaw muntanji mmewġa.	
Togħla t-temperatura u jkollna ħafna sħana.	
Tiççaqlaq l-art u jseħħ terremot.	
Jseħħu maltempati bis-silġ u l-borra.	

(3)

Taħriġ 5

Kompli dawn is-sentenzi dwar it-terremoti u l-vulkani.

- a. Bl-iskala Richter inkun naf
-
- b. Aktar ma' post ikun vicin tal-epicentru ta' terremot
-
- c. Il-ħawt tal-magma
-
- d. Vulkan attiv
-
- e. Vulkan mejjet
-

(10)

Taħriġ 6

Ikteb paragrafu dwar it-terremot li studjat dwaru. Semmi fejn seħħ, il-qawwa u l-ħsara jew problemi li kkaġuna.

.....

.....

.....

.....

.....

.....

.....

(8)

Taħriġ 7

Disinn 6 juri mappa tad-dinja.

- a. Fuq **disinn 6** semmi u mmarka b'kulur isfar żewġ deżerti sħan. (4)
- b. Fuq **disinn 6** semmi u mmarka bil-lapes żewġ deżerti keshin (4)



Disinn 6 – Mappa tad-dinja

Taħriġ 8

Disinn 7 juri erba' graffs. L-ewwel tnejn juru t-temperatura u xita f'deżert sħun waqt li l-graffs l-oħra juru t-temperatura u x-xita f'deżert kiesaħ.

- a. Aghmel sing taht it-twegiba t-tajba billi tuza l-**graffs ta' deżert sħun**.
- (i) F'dan id-deżert sħun it-temperatura qatt ma tinzel taht (**it-30°C, l-10°C, l-25°C**).
- (ii) L-aktar xahar kiesaħ f'dan id-deżert sħun huwa (**Frar, Settembru, Jannar**) fejn it-temperatura tinzel (**15°C, 22°C, 30°C**).

- (iii) L-aktar xahar sħun f'dan id-deżert sħun huwa (**Marzu, Diċembru, Lulju**) fejn it-temperatura togħla sa (**25°C, 35°C, 45°C**).
- (iv) F'dan id-deżert sħun l-aktar li tinżel xita huwa fix-xhur ta' (**Novembru u Diċembru, Marzu u April, Mejju u Ġunju**).
- (v) B'kollox fix-xahrejn li l-aktar tagħmel xita tinżel (**60mm, 80mm, 20mm**).
- (vi) B'kollox f'dan id-deżert sħun hemm (**4, 6, 3**) xhur fejn ma tinżilx qatra xita.
- (vii) F'sena sħiħa tagħmel madwar (**120mm, 70mm, 1,200mm**) ta' xita.

(7)

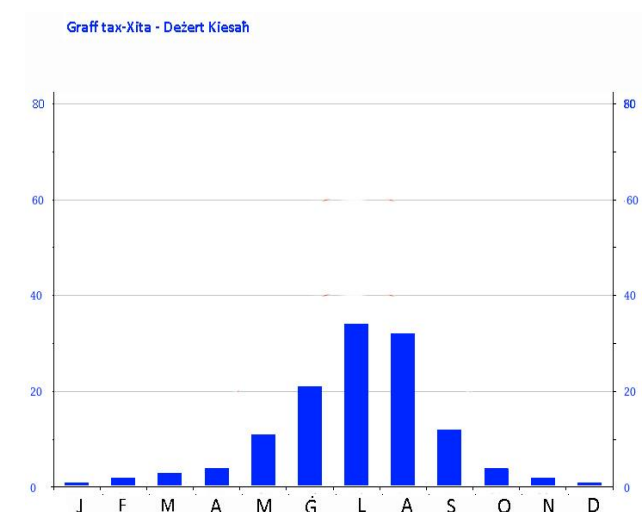
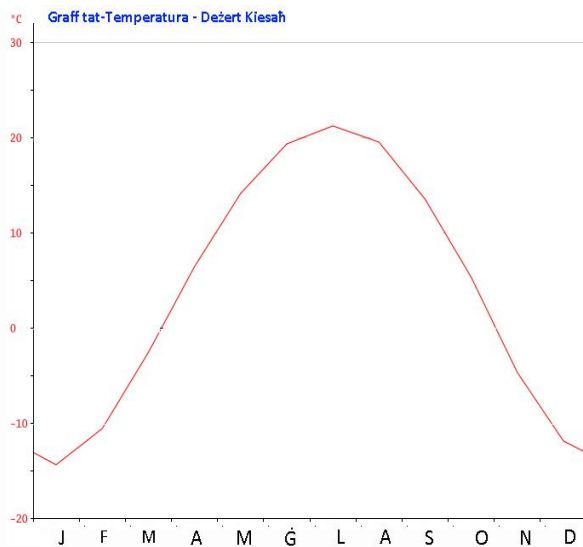
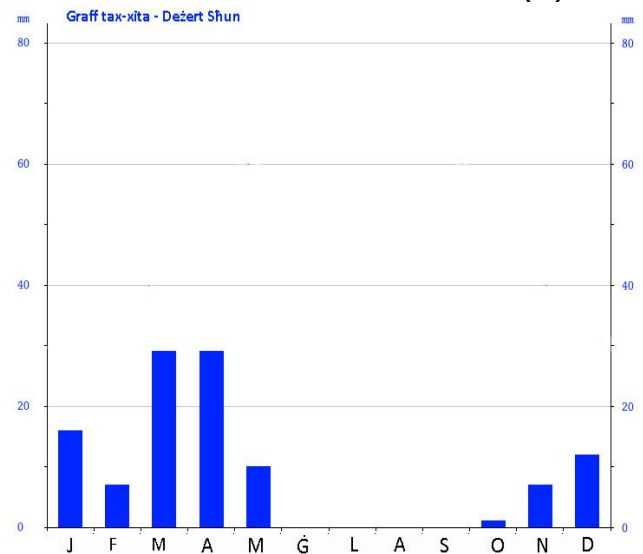
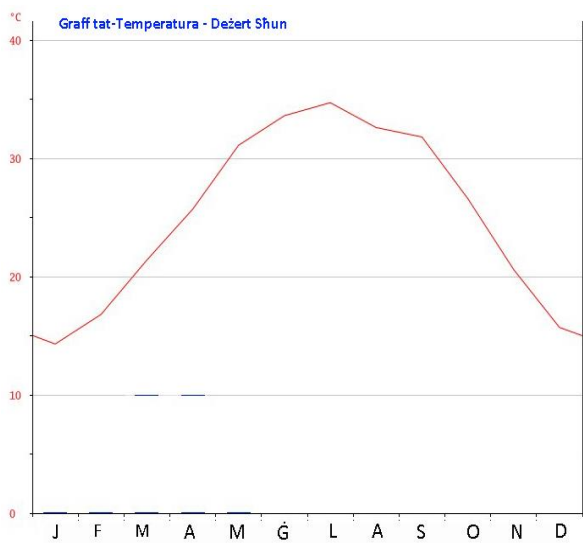

Disinn 7 – Graffs tat-temperatura u tax-xita

- b. Ikteb erba' sentenzi dwar it-temperatura u x-xita f'deżert kiesaħ billi tuża l-graffs ta' deżert kiesaħ f'**disinn 7**.

.....

.....

.....

.....

.....

.....

.....

.....

.....

.....

.....

(8)

- c. Spjega fil-qosor kif annimali u pjanti li nsibu f'deżert sħun jew f'deżert kiesaħ jaddattaw ruħhom biex jgħixu f'dan l-ambjent.

Annimali:

.....

Pjanti:

.....

(6)

YEAR 8

GEOGRAPHY

TIME: 1 hour

Name: _____

Class: _____

Answer all questions.

Question 1

Figure 1 shows a map of North America.

Answer the following questions.

- h. Name two countries that border North America.
..... (2)
- i. In which country is the city of San Francisco found?
..... (1)
- j. What is the name of the ocean closest to the city of Washington DC?
..... (1)
- k. Name the lakes found between Canada and the United States.
..... (1)
- l. In which ocean are most of the Canadian islands found?
..... (1)
- m. Which of these countries do not have a coast touching the Gulf of Mexico?
(Choose from: Mexico, Canada, United States, Greenland, Guatemala).
..... (3)
- n. To which country does Alaska belong to?
..... (1)



Figure 1 – Map of North America

Question 2

Figure 2 shows a world time zone map.

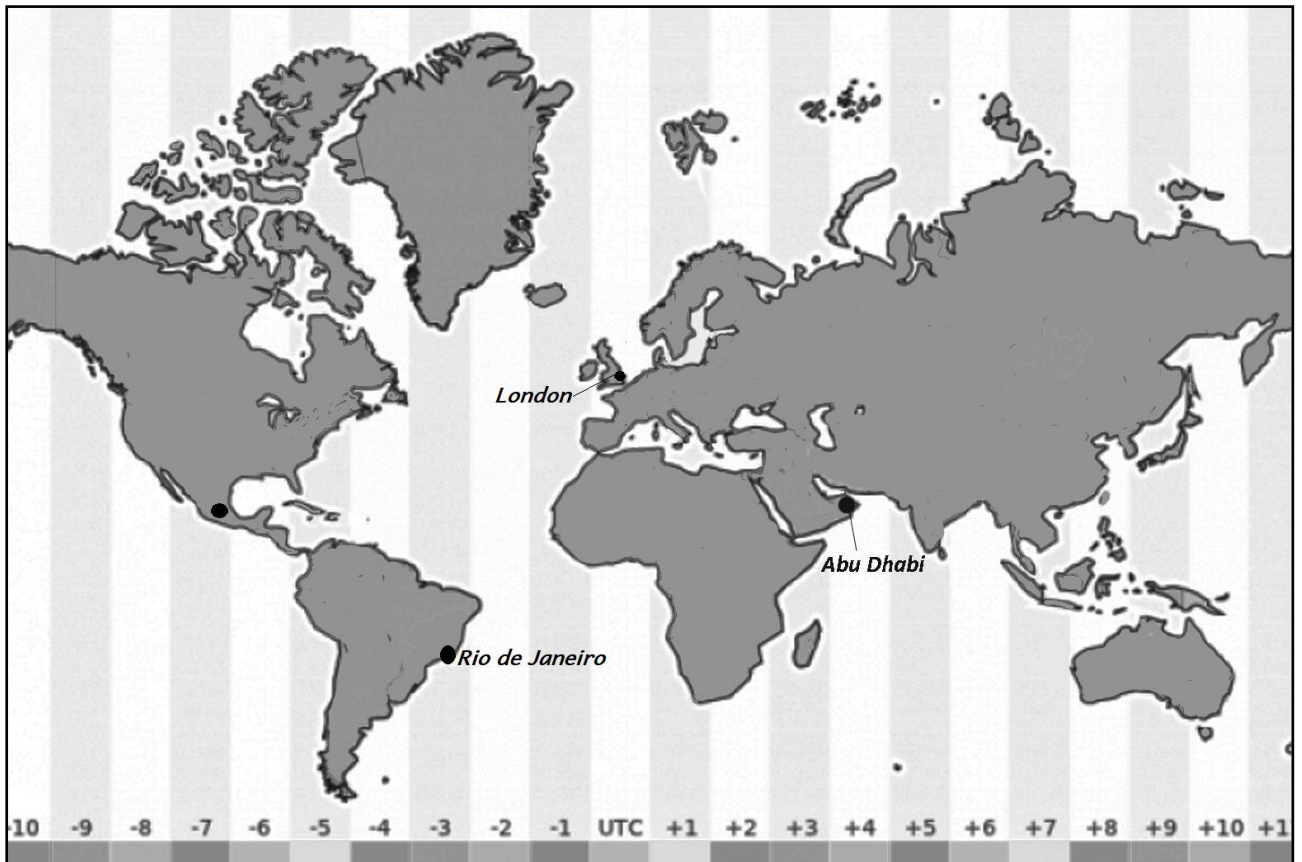

a. The time in London is 8 o'clock in the morning (8:00). What is the time in

Rio de Janeiro? _____

Abu Dhabi? _____

Malta? _____

(6)

Stephen, who lives in Naxxar is a great Formula 1 Grand Prix fan. He searched on the internet and found that the next race is going to take place in Abu Dhabi. He found also that the race is going to start at 5:00 in the afternoon (17:00) Abu Dhabi time. On the day of the race Stephen switched on the television before 5:00 but to his disappointment he realised that the race had already finished. So Stephen concluded that the information he found on the internet was incorrect.

b. Do you think Stephen's conclusion is correct? (Tick ✓ the correct box)

Yes

No

(1)

c. Give a reason for your answer.

.....(3)

Question 3

Figure 3 shows some natural disasters that occur from time to time all around the world.



Figure 3 – Natural disasters

c. With the help of **Figure 3** explain what is a natural disaster.

.....
.....
.....

(2)

d. Name **FOUR** examples of natural disasters. (You can name others not shown in the pictures).

.....
.....

(4)

- c. Write a paragraph on a natural disaster you have studied about. Describe the natural disaster, where did it happen and the damage caused.

The natural disaster I am going to write about is:

.....

.....

.....

.....

.....

.....

.....

.....

.....

(8)

Question 4

Figure 4 shows the interior structure of the Earth.

- g. Label **Figure 4** with these terms:

outer core inner core crust mantle

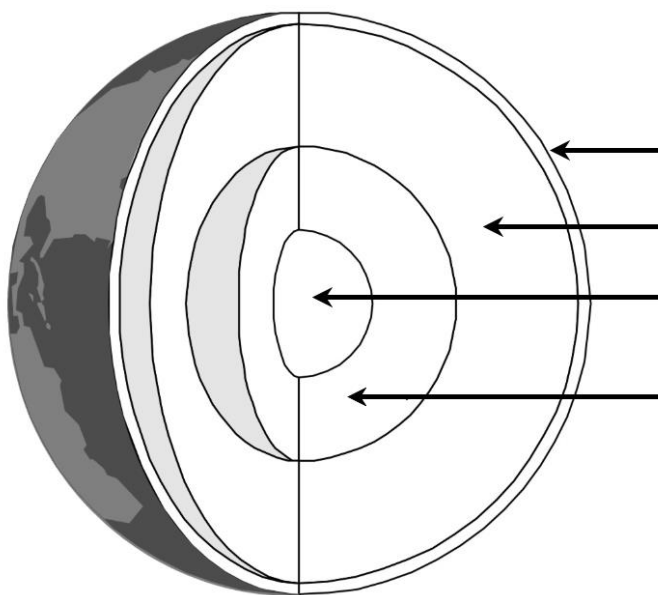

Figure 4 – The interior of the Earth

(4)

h. On **Figure 4** mark the convection currents. (2)

i. What is causing these convection currents to move in a circular pattern?

.....
..... (2)

j. What happens when these convection currents reach the crust of the Earth?

.....
..... (2)

k. **Figure 5** shows a cross-section of a volcano. Label the diagram with the following terms:

lava flow	magma chamber	ash
layers of ash and lava	volcanic vent	crater

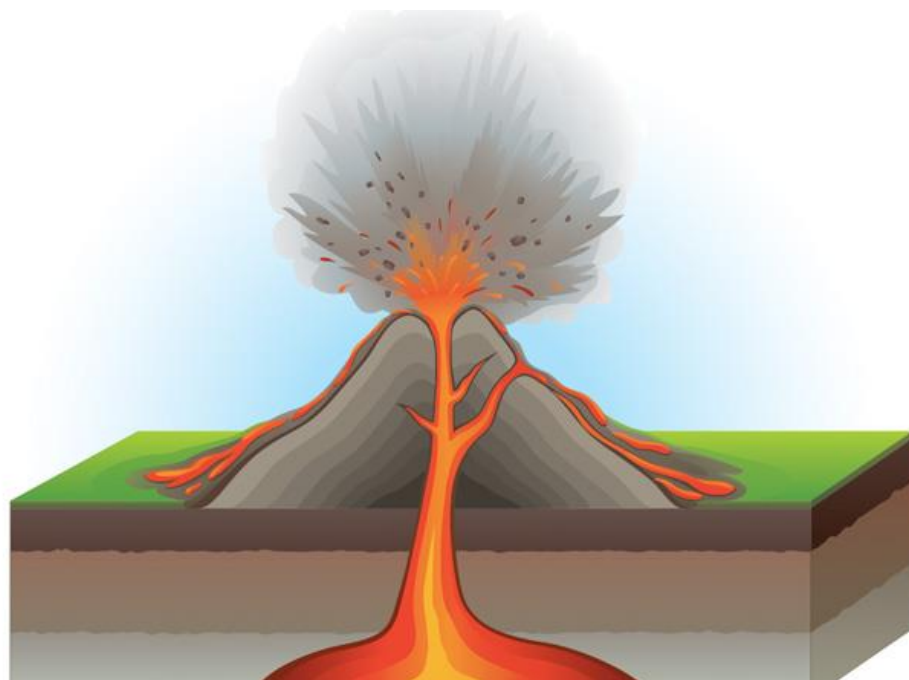

Figure 5 – Cross-section of a volcano

(6)

I. What happens when tectonic plates move? Tick (✓) the correct answers.

A volcano may erupt.	
Rain falls in the form of heavy thunderstorms.	
Fold mountains may form.	
Temperature rises resulting in a heat wave.	
The Earth's crust shakes resulting in an earthquake.	
Blizzards of snow occur.	

(3)

Question 5

Complete these sentences about earthquakes and volcanoes.

- f. With the Richter Scale we would know
- g. The closest a place is to the epicentre of an earthquake
- h. The magma chamber
- i. An active volcano
- j. An extinct volcano

(10)

Question 6

Write a paragraph on an earthquake you have studied about. State where it happened, its magnitude and the damage and problems caused.

.....

.....

.....

.....

.....

.....

.....

(8)

Question 7

Figure 6 shows a world map.

- c. On **Figure 6** name and mark in yellow **two** hot deserts. (4)
- d. On **Figure 6** name and mark in pencil **two** cold deserts. (4)

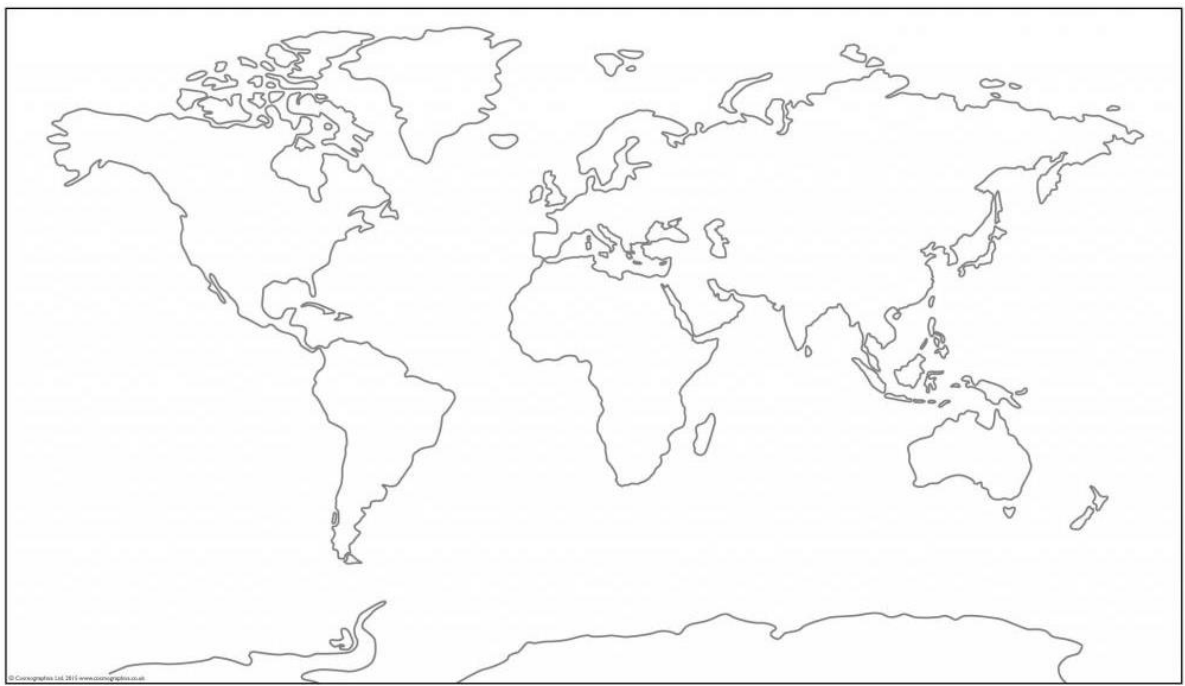

Figure 6 – Map of the World

Question 8

Figure 7 shows four graphs. The first two show temperature and rainfall in a hot desert while the other two show temperature and rainfall in a cold desert.

d. Underline the correct answer by using the **graphs of the hot desert**.

- (viii) In this hot desert temperature never falls below (**30°C, 10°C, 25°C**).
- (ix) The coldest month in this hot desert is (**February, September, January**) where the temperature falls to (**15°C, 22°C, 30°C**).
- (x) The warmest month in this hot desert is (**March, December, July**) where the temperature rises to (**25°C, 35°C, 45°C**).
- (xi) In this hot desert rain falls mostly during the months of (**November and December, March and April, May and June**).
- (xii) The total of rain that falls during the wettest two months is (**60mm, 80mm, 20mm**).
- (xiii) In all in this hot desert there are (**4, 6, 3**) months where not a single drop of rain falls.
- (xiv) The annual average rainfall of this hot desert is about (**120mm, 70mm, 1,200mm**).

(7)

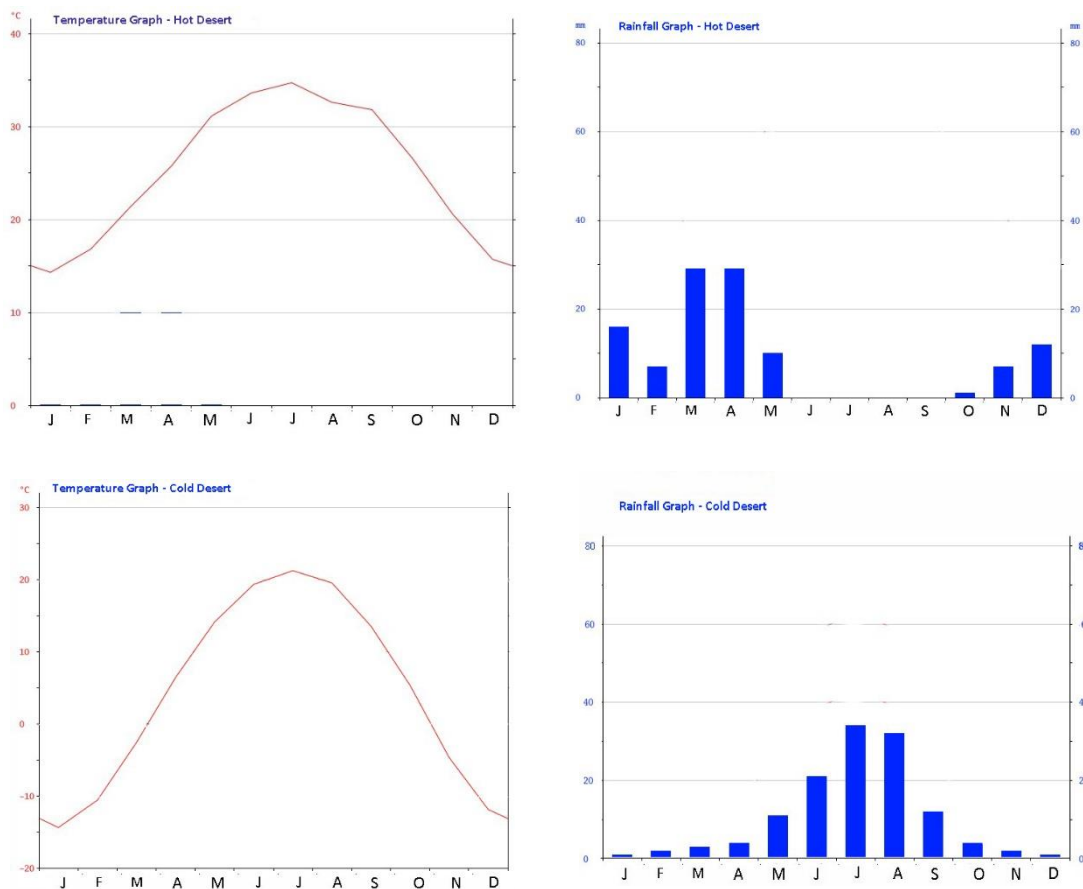

Figure 7 – Temperature and rainfall graphs

- e. Write **four** sentences about the temperature and rainfall of a cold desert by using the graphs of a cold desert in **Figure 7**.

.....

.....

.....

.....

.....

.....

.....

.....

.....

.....

(8)

- f. Explain briefly how animals and plants adapt and manage to live in either a hot or a cold desert.

Animals:

.....

Plants:

.....

(6)